

# **Effect of Heat Balancer Technique applied for Heavy Section**

## **Ductile Iron Castings.**

**\*Kazuya Ishikawa**

MATSUE DIVISION

Yanmar Casting Technology

kazuya\_ishikawa@yanmar.co.jp

**Tomokatsu Kotani**

MATSUE DIVISION

Yanmar Casting Technology

**Tomoya Ogino**

CASTING TECHNICAL CENTER

Yanmar Casting Technology

**Haruki Itofuji**

ADSTEFAN/CASTING-SOLUTION CENTER

University of Tohoku

### **ABSTRACT**

Our foundry has produced flywheel castings made of ductile iron for diesel engines. Their average section thickness and diameter were about 150mm and 1120mm respectively. It was very important to make weight adjusting minimum for flywheels. Therefore, castings should be free from any shrinkage. In the case of plate-like casings, riserless design would not be successful for the countermeasure of shrinkage but riser design had been adopted usually. Conventionally, electric heating device called slim riser had applied for them as the shrinkage countermeasure. However, the electric device had not been enough to avoid shrinkage defects and the tendency was irregular. Conventional riser and riserless design were also tried but they were worse than the electric device on the shrinkage countermeasure. Finally, heat balancer technique designed as a kind of riser was applied for the shrinkage countermeasure. Heat balancer was not opened in atmosphere but was always closed. This was the reason why the control of solidification pressure was very important to avoid shrinkage besides heat control. Shrinkage defects were significantly reduced by heat balancer technique. There were flywheel castings which even had no shrinkage at all. If the technique was

ideally succeeded, there would be no shrinkage even in heat balancer also. This was typical point. Application of heat balancer technique and the results will be introduced in The 12<sup>th</sup> Asian Foundry Congress.

**Keywords:** Riser design, Ductile iron, Shrinkage, Casting

## 1 INTRODUCTION

It is rather difficult to produce shrinkage free ductile iron castings as general opinion among engineers, especially plate like ones. In general practice, riser and chiller have been used as the countermeasure of shrinkage. The basic idea comes from keeping directional solidification toward riser. Flywheel for marine engine, which was round and plate like shape, had been tried to produce shrinkage free quality. The quality was required to avoid not only defects appeared on the machining surface, but also defects occurred inside of wall thickness. Flywheel had to be shrinkage free, as possible. This was the reason why such defects affected to the static balance weight in casting, and furthermore, they made engine irregular vibration during operation. However, the quality was never satisfied in good level, so far.

In this study, heat balancer theory proposed by H. Itofuji [1-3] was applied for flywheel to get shrinkage free quality. According to H. Itofuji, if it was well designed and the cast condition was set in good too, there would be no shrinkage in not only casting but also heat balancer itself. The results in practice will be introduced as follows.

## 2 HEAT BALANCER TECHNIQUE

According to H. Itofuji [1-3], casting is given balance on temperature by heat balancer and therefore expansion force during solidification is controlled to avoid shrinkage. On the other hand, N. Nakayama et.al [4] have evaluated that it's a kind of riser. The idea and design procedure of heat balancer is introduced as follows.

The first of all, riser or riserless is judge using Formula (1), (2) and (3). In the case of round shape casting like flywheel, the shape factor is calculated using an example shown in Figure 1.

$$Mc = V/S \quad [cm] \quad >3.0cm \rightarrow \text{Riserless} \quad (1)$$

V; Volume [cm<sup>3</sup>], S; Surface area [cm<sup>2</sup>]

$$F = (L+W)/T \quad [cm] \quad (2)$$

L; Length [cm], W; Width [cm], T; Thickness [cm]

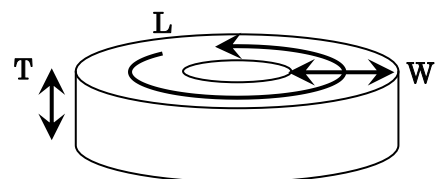

Figure 1: L, W, and T of flywheel used in Formula (2)

$$I = Mc/F \quad [cm] \quad >0.5cm \rightarrow \text{Riserless} \quad (3)$$

I; Safety index for riserless

If riserless design was impossible, heat balancer would be applied instead of riser. Heat balancer is designed using Formula (4), (5), (6) and (7). Heat balancer should be the shape of dome as shown in Figure 2. The effective distance of heat balancer is concerned as 8 times against wall thickness of casting [3]. Other researcher reported that it was 4.0~6.5 times as riser [4]. In this study, 8 times of wall thickness was chosen. The number of heat balancer was calculated using Formula (8) and the effective distance was illustrated in Figure 3.

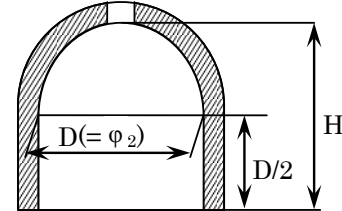

Figure 2: Shape for heat balancer

$$Mb = 1.2 \times Mc \quad (4)$$

$$\varphi_1 = 6Mb \quad (5)$$

$$\varphi_1 = 6 \times 1.2 \times Mc \quad (6)$$

$$\varphi_2 = 0.8 \times \varphi_1 \quad (7)$$

$\varphi_1$ ; Diameter of sand doom,  $\varphi_2$ ; Diameter of insulating doom

$$\ell = \varphi_2 + 2(\alpha \times T) \quad (8)$$

$\alpha$ ; Coefficient as effective distance = 8

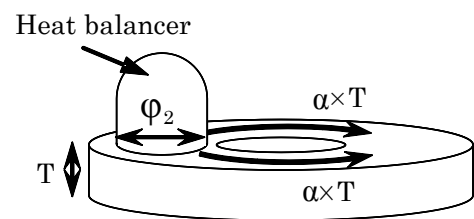

Figure 3: Concept of effective distance

To succeed heat balancer, it is very important to keep the following condition;

- $\varphi : H = 1 : 1$
- Design it at the final solidification area
- Design flow-off on it to compensate liquid shrink before solidification
- Use insulating material to minimize volume

### 3 EXPERIMENTAL PROCEDURE

Dimension and casting design for flywheel are shown in Figure 4.

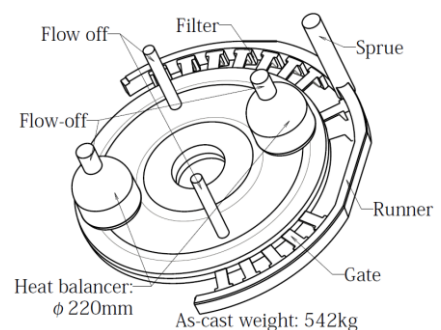
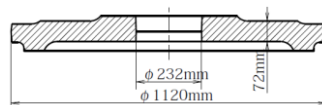

Figure 4: Dimension and heat balancer cast design for flywheel

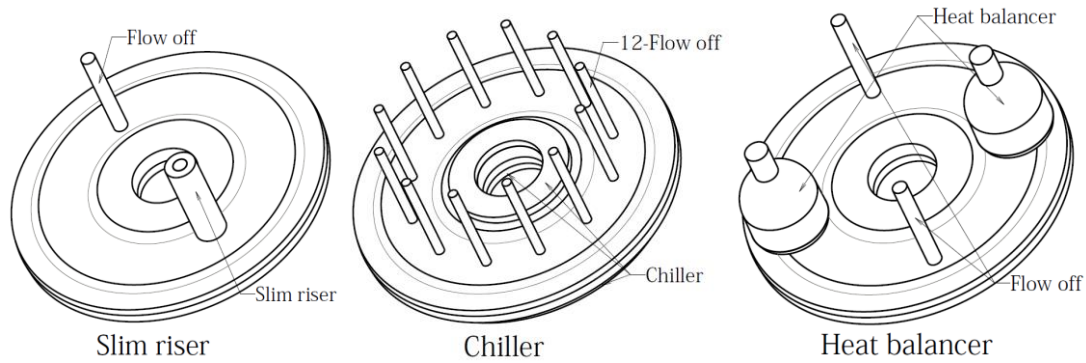
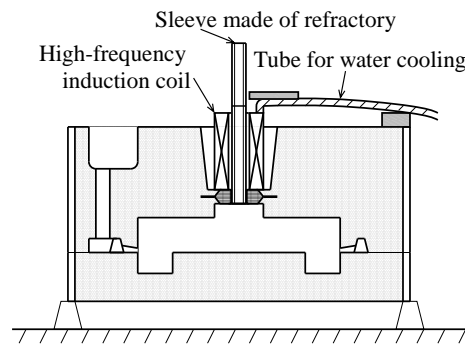

Figure 5: Conventional and heat balancer cast designs

Conventional cast designs are shown in Figure 5. Their runner systems were the same as shown in Figure 4.

Here, the slim riser is explained. Slim riser cast design is shown in Figure 6. Slim riser looks like a flow-off but it is heated by high frequency induction coil during the solidification of casting. Therefore, it can be riser. As compared with the conventional riser, the



Illustration



Photograph

Figure 6: Slim riser cast design

volume of riser can be reduced from one tenth to one twentieth.

Furan silica sand was used as molding process. The compressive strength was set as 4.6~5.7MPa. Base iron was prepared using 3ton high frequency induction furnace. Carbon equivalent of base iron was aimed 4.15~4.25mass% for making graphite good volumetric expansion and avoiding graphite dross. Pouring temperature was set  $1320 \pm 20^\circ\text{C}$  in ladle. As-cast appearance after shaking out and shot blasting is shown in Figure 7.



Figure 7: As-cast appearance after shaking out and shot blasting

Ultrasonic testing (UT) was conducted on machined surface after visual testing (VT). The test condition is shown in Table 1. Acceptance criteria were set as less than 5% of fault echo. If defects were detected, such area was cut using band saw and checked by liquid penetrant testing (PT) after static balance weight was measured on machine table. Defects detected by UT were analyzed using computer aided engineering (CAE) system.

Table 1 Conditions for ultrasonic testing

Gain	45.0dB
Range	100mm
Sonic velocity	5.58km/s
Frequency	2MHz
Probe diameter	φ15mm
Acceptance criteria	Fault wave <5%

## 4 TEST RESULTS AND CONSIDERATIONS

### 4.1 Chemical composition and mechanical properties

Chemical composition of flywheels in each cast design is shown in Table 2. Mechanical properties of separately cast test sample which was poured the same treated iron with each flywheel are shown in Table 3. All mechanical properties were satisfied those of JIS G 5502 FCD450-10.

Table 2 Chemical composition of flywheels in each cast design, mass%

	C	Si	Mn	P	S	Mg	Ce
Heat balancer	3.57	2.39	0.20	0.015	0.010	0.042	0.012
Chiller	3.72	2.36	0.26	0.026	0.009	0.043	0.012
Slim riser	3.70	2.32	0.27	0.025	0.009	0.050	0.012

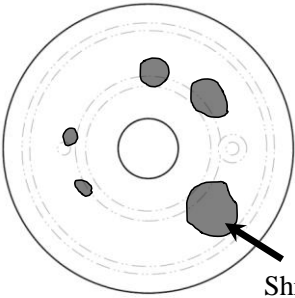
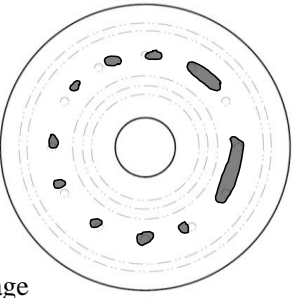
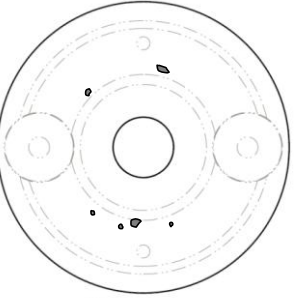

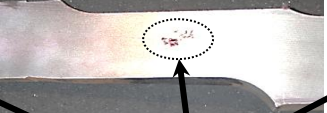

Table 3 Mechanical properties of separately cast test sample

Test sample (JIS G 5502)	Tensile strength [MPa]	0.2% proof stress [MPa]	Elongation [%]	Reduction in area [%]	HB [10/3000]
FCD450	≥ 450	≥ 280	≥ 10	-	140~210
φ25mm Knoch-off	479	298	20	19	170

### 4.2 Ultrasonic testing, visual testing and liquid penetrant testing

After machining, no visual defect was found on that surface. Then, UT was conducted on the machined surface. The results are shown in Table 4. It is clear that the amount of shrinkage in heat balancer cast design was extremely reduced than those in conventional cast designs. Shrinkage was not observed under heat balancer but some were observed under peripheral area of flaw off. The part of the highest fault echo detected by UT was cut using band saw and PT was conducted on the section surface. The results are also shown in Table 4. Compared with conventional cast designs, quite a small size of indication was scarcely observed in the area detected flaw echo by UT in the case of heat balancer cast design.

Table 4 Results of UT and PT in conventional and heat balance cast designs

	Slim riser	Chiller	Heat balancer
UT			
PT			

### 4.3 Shrinkage area ratio and static balance weight

The results of static balance weight test and shrinkage area ratio by UT are shown in Figure 8. It is clear that the balance weight became small when the amount of shrinkage reduced. In other words, adjustment weight was the smallest in the case of heat balance cast design because of the smallest amount of shrinkage.

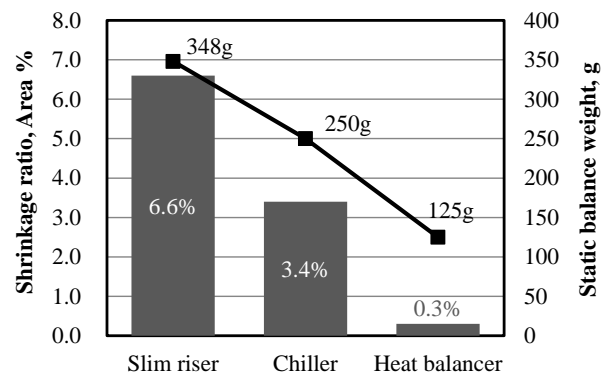

Figure 8: Comparison of static balance weight among cast designs

### 4.4 Total cost

Total production cost including scrap down was compared among cast designs. The results are indicated as index number and shown in Figure 9. The standard cast design is slim riser. Although the melting cost of heat balancer cast design was higher than that of conventional cast designs, the total cost was the cheapest among three cast designs because of no scrap down. Furthermore, a static balance

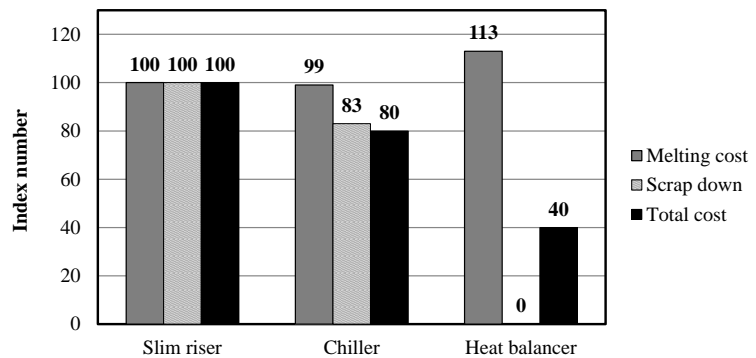

Figure 9: Comparison of total cost performance among cast designs

weight of flywheel by heat balancer cast design was much better than that of conventional cast designs.

#### 4.5 Chunky graphite

As shown in Figure 10, extraordinary pattern and color was observed visually on machined surface under heat balancer. As the result of micro analysis, chunky graphite structure was observed at the area. The result is shown in Figure 11. The mechanical properties at such area were examined and they were compared with those at sound area. The results were compared with close neighbor in the same section. The results are shown in Table 5. It was known that tensile strength and elongation at chunky graphite area was lower than sound area. Although there has been no functional problem as flywheel so far, chunky graphite should be avoided getting better reliability on machine design.



Figure 10: Appearance after finish machining

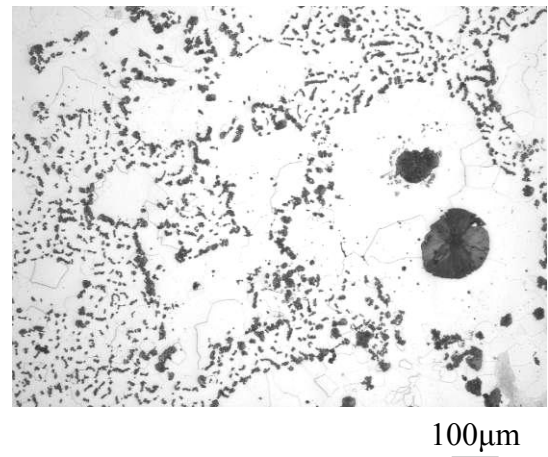

Figure 11: Microstructure observed at extraordinary pattern and color under heat balancer (5% nital etch)

Table 5 Mechanical properties at extraordinary pattern and color under heat balancer

Sampling area	Tensile strength [MPa]	0.2% proof stress [MPa]	Elongation [%]	Reduction in area [%]	HB [10/3000]
Chunky graphite	326	259	3	-	161
Sound	426	269	15	-	154

Chunky graphite may be expected to avoid by the following countermeasure [5];

- Si content should be lower like 2.0~2.3mass%.
- The stoichiometry amount of counterbalance elements like Sb should be added against Ce content.
- If neck-down core was used for heat balancer, metal Al and moisture should not contained in it.
- Solidification time should be reduced using chillers, as short as possible.

## 4.6 CAE analysis

Recently,  $G/\sqrt{R}$  so called Niiyama index has been popular to forecast shrinkage. However, it was found that  $G/\sqrt{R}$  did not fit the results of UT in the case of heat balancer. An example of CAE analysis is shown in Figure 12. There was almost no shrinkage between heat balancer actually but CAE analysis showed the high possibility of shrinkage.

To improve the accuracy of CAE analysis, it is considered that precise data on the quantity of graphite crystallization relating to carbon equivalent

during solidification under some cooling rate should be clear because they must be incorporated as expansion pressure. New index may be required for the accurate CAE analysis.

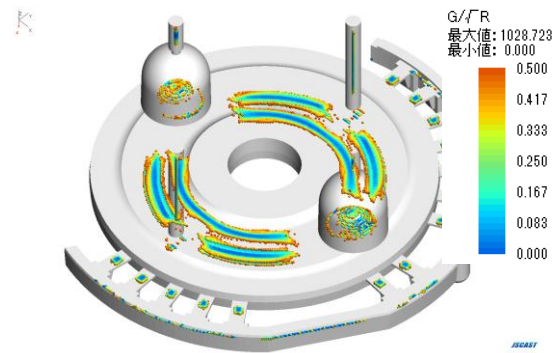

Figure 12: An example of CAE analysis

## 5 CONCLUSIONS

Heat balancer, which was a kind of riser, was applied to flywheel for marine engine to avoid shrinkage. As the result, follows were proved;

- Shrinkage area ratio decreased drastically in comparison with conventional products.
- By decreasing shrinkage ratio, static balance weight could be significantly improved.
- Total production cost including moldability and scrap down could be reduced significantly.

## ACKNOWLEDGMENT

I'm extremely grateful to Ms. Risa Satou in Yanmar Casting Technology and Mr. Akihide Kawabata in Tsuchiyosi Industry Co., Ltd. for all their help to this study.

## REFERENCES

- [1] H. Itofuji, Application of The Site Theory on The Quality Control of Heavy Section Spheroidal Graphite Cast Iron, K. D. Millis World Symposium on Ductile Iron, SC, Oct. 20(1993).
- [2] H. Itofuji, Study on Graphite Spheroidization in Cast Irons, Thesis of Doctor Degree, Kyoto University, (1993).
- [3] H. Itofuji, Theory and Practical Examples of Cast Design for Heavy Section Ductile Iron Castings, Text for 1997 Seminar, Japan High Grade Cast Iron Association, Feb. 14(1997).
- [4] N. Nakayama et al., Cast Technique of Castings Iron, Japan Cast Iron Foundry Association, 67, Feb. (1998)
- [5] H. Itofuji, Cause and Countermeasure of Chunky Graphite Crystallization in Heavy Section Spheroidal Graphite Cast Irons, Journal of Japan Foundry Engineering Society, 84.3, 152, (2012)